



Manual

Version
March 2022



BATTERY COMMUNICATION INTERFACE (BCI)



User Manual Battery Communication Interface (BCI)

Dear customer,

This manual contains all the necessary information to install, use and maintain the Battery Communication Interface (BCI). We kindly ask you to read this manual carefully before using the product. In this manual the Battery Communication Interface will be referred to as the BCI. This manual is meant for the installer and the user of the BCI. Only qualified personnel may install and perform maintenance on the BCI. Please consult the index at the start of this manual to locate information relevant to you.

During the use of the product, user safety should always be ensured, so installers, users, service personnel and third parties can safely use the BCI.

Copyright© Super B All rights reserved. Licensed software products are owned by Super B or its subsidiaries or suppliers, and are protected by national copyright laws and international treaty provisions. Super B products are covered by Dutch and foreign patents, issued and pending. Information in this publication supersedes that in all previously published material. Specifications and price change privileges reserved. Super B is a registered trademark of Super B.

For more information please contact:

Super B Lithium Power B.V.
Europalaan 202
7559 SC Hengelo (Ov) The Netherlands
Tel: +31(0)88 00 76 000
E-mail: info@super-b.com
www: www.super-b.com

Table of content

| | |
|--|-----------|
| 1. Safety guidelines and measures | 5 |
| 1.1. General | 5 |
| 2. Introduction | 5 |
| 2.1. Product description | 5 |
| 2.2. Intended use | 6 |
| 2.3. Glossary of Terminology | 6 |
| 2.4. Used symbols | 7 |
| 3. Product specifications | 7 |
| 3.1. Typical setup of the BCI | 7 |
| 3.2. Product features | 8 |
| 3.3. BCI functional behaviour | 9 |
| 3.3.1. General | 9 |
| 3.3.2. Functionality of the power inputs | 9 |
| 3.3.3. BCI States | 11 |
| 3.3.4. Driver behaviour | 13 |
| 3.4. BCI control functions | 15 |
| 3.4.1. Auto-on | 15 |
| 3.4.2. SoC shutdown/Switch-OFF | 15 |
| 3.4.3. Reset | 15 |
| 4. General product specifications | 16 |
| 4.1. Electrical specifications | 16 |
| 4.2. Mechanical specifications | 16 |
| 4.3. Environmental specifications | 17 |
| 4.4. Scope of delivery | 18 |
| 4.5. Connections, indicators and controls | 18 |
| 4.5.1. CAN connector pinout (Master/Slave) | 19 |
| 4.5.2. J3 (I/O Connection 10) | 19 |
| 4.5.3. J4 (I/O Connection 10) | 20 |
| 4.5.4. Indicators | 20 |
| 4.6. Peripheral equipment | 21 |
| 5. Installation | 22 |
| 5.1. General information | 22 |
| 5.2. Unpacking | 22 |
| 5.3. Required tools for installation | 22 |
| 5.4. Placement of the BCI | 22 |
| 5.5. Connection wires | 22 |
| 5.6. Electrical installation | 23 |
| 5.6.1. Electrical installation - BCI power from battery bank | 23 |

| | | |
|------------|--|-----------|
| 5.6.2. | Electrical installation - BCI externally powered | 25 |
| 5.6.3. | Manual control | 26 |
| 5.6.4. | Pre-charge selection | 27 |
| 5.7. | CAN Bus | 29 |
| 5.7.1. | General information | 29 |
| 5.7.2. | Connecting the CAN network cables | 29 |
| 5.7.3. | CAN Bus network topology | 30 |
| 5.7.4. | Termination Resistors | 30 |
| 5.7.5. | CAN bus power | 30 |
| 5.7.6. | Integrating CAN Protocol | 31 |
| 5.7.7. | General purpose I/O | 31 |
| 6. | BCI use | 31 |
| 6.1. | General information | 31 |
| 6.2. | Configuring the BCI and the battery bank | 32 |
| 6.3. | Battery ID's | 32 |
| 6.3.1. | Battery ID renumbering procedure | 32 |
| 6.3.2. | Battery layout | 36 |
| 6.3.3. | Input level configuration | 37 |
| 6.3.4. | BCI Modules | 38 |
| 6.3.5. | Pre-charge adjustment | 39 |
| 6.3.6. | General settings: Automatic control | 40 |
| 6.3.7. | General settings: State-of-charge switch-OFF level | 41 |
| 6.3.8. | Saving a configuration | 42 |
| 6.4. | Status and control | 43 |
| 6.5. | Status of the battery bank | 44 |
| 7. | Inspection and cleaning | 47 |
| 7.1. | General information | 47 |
| 7.2. | Inspection | 47 |
| 7.3. | Cleaning | 47 |
| 7.4. | Maintenance | 47 |
| 8. | Storage | 48 |
| 9. | Transport | 48 |
| 10. | Disposal | 48 |
| 11. | Troubleshooting | 49 |
| 12. | Warranty and liability | 50 |

1. Safety guidelines and measures

1.1. General

- Treat the BCI as described in this manual.
- Do not disassemble, crush, puncture or shred the BCI.
- Never install or use a damaged BCI
- Do not expose the BCI to heat or fire.
- Do not remove the BCI from its original packaging until required for use.
- The BCI shall not be used outside the electrical and mechanical specifications as specified in this manual.
- Do not mix Li-ion batteries of different capacity, size or type. Only use Super-B Li-ion traction batteries with the BCI.
- Retain the original product documentation for future reference.
- Always take safety precautions when working on battery systems.
- Never short circuit the Li-ion battery.

⚠ Warning! Only trained experts shall handle or install a BCI and/or the related battery systems. These systems can deliver very large currents and/or high voltages.

⚠ Caution! A caution sign indicates problems may occur if a procedure is not carried out as described. It may also serve as a reminder to the user.

2. Introduction

2.1. Product description

The Battery communication Interface (BCI) is a device intended to control contactors or relays that must be used to protect Super B Li-ion batteries from improper use. The BCI collects data from one or multiple Li-ion batteries by a CANopen communication bus. This data contains information about the status and the current use of the Li-ion batteries. If one or more Li-ion batteries reports an issue, the BCI will turn off the contactors and protect the Li-ion batteries. Although the BCI can be used to manage a single Li-ion battery, it is intended to collect data from multiple Li-ion batteries in series and/or parallel for controlling contactors. Other typical functions are:

- Control pre-charge functionality. Therefore, an additional contactor and resistor is needed tailored to the application.
- Protocol conversions (depending on BCI software version).
- Control charger by CAN or charge enable signal (depending on BCI software version).



2.2. Intended use

Potential applications to use the BCI in combination with Li-ion batteries from Super B are:

- Off grid applications
- Marine applications
- Medium for (renewable) energy storage (traction)
- Battery for vehicles.

Depending on the application it can be necessary that additional components are used to assure that the installation is compliant with the applicable regulations. See chapter 5.6 for information on electrical installations.

The BCI is sold as a single device, the customer is expected to source necessary components for protecting the Li-ion batteries. Super B cannot be held responsible for installations made by the customer.

Super B also offers the option of supplying the complete installation. This can be a standard solution or a custom solution. The standard solution can be found on our website or by contacting sales. The custom solution needs to be aligned with your sales and application engineering contact.

If this manual does not cover or address your application, please contact Super B. Only qualified personnel may install and perform maintenance on the complete system - always refer to chapter 1 of this manual for safety guidelines.

The boundaries of the BCI use, as described in this manual should always be upheld. The BCI may not be used in medical, or in aviation related applications. The BCI may not be used for any purposes other than described in this manual. Using the BCI for any other purposes will be considered improper use and will void the warranty of the product. Super B cannot be held responsible for any damage caused by improper, incorrect, or unwise use of the product. Please read and understand this entire manual carefully before using the product.

2.3. Glossary of Terminology

| | |
|-----------------------|---|
| BMS | Battery Management System |
| BIB | Battery Interface Box |
| BCI | Battery Communication Interface |
| LiFeP04 | Lithium Iron Phosphate |
| Be in Charge Software | PC application for monitoring control and configuration |

| | |
|------------|---|
| DC-bus | Load / charger side of main contactor(s) |
| SoC | State of charge |
| CANopen | CAN bus protocol |
| 48V system | A system that consists of 4 batteries in series |
| 24V system | A system that consists of 2 batteries in series |

Table 1. Glossary of Terminology

2.4. Used symbols

The following icons will be used throughout the manual:

- ⚠ **Warning!** A warning indicates severe damage to the user and/or product may occur when a procedure is not carried out as described.
- ⚠ **Caution!** A caution sign indicates problems may occur if a procedure is not carried out as described. It may also serve as a reminder to the user.

3. Product specifications

3.1. Typical setup of the BCI

Figure 1, depicts a typical setup of the BCI. The circuit shows the interconnections of the BCI in an installation to protect the Li-ion battery (bank).

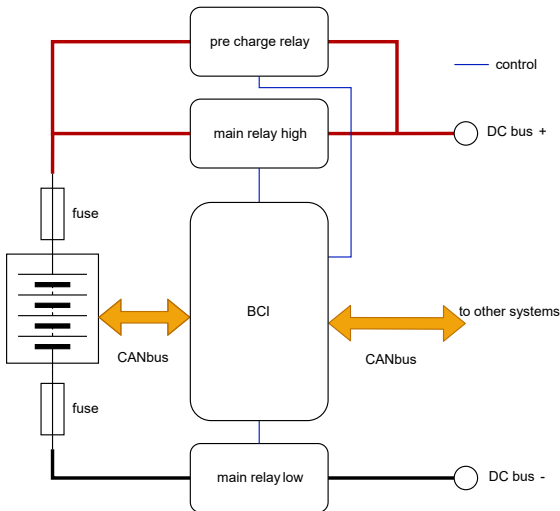
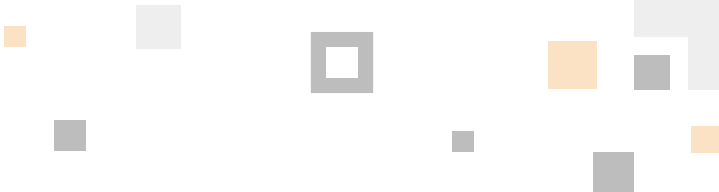

Figure 1. Typical BCI setup

3.2. Product features

- Three dry outputs to control the minus, the plus, and the pre-charge contactor of the Li-ion battery bank.
- Four galvanic isolated inputs for manual operation (not shown in Figure 1).
- Collecting the status and alarm messages of all the Li-ion batteries connected to the CAN bus. In case of an alarm from one of the Li-ion batteries the BCI will control the contactors to disconnect from the DC bus.
- Scanning the CAN bus to see if all the Li-ion batteries that are configured are present. In case of a missing Li-ion battery, the BCI will go in alarm state and will control the contactors to disconnect the Li-ion battery bank from the DC bus.
- Collecting information of all Li-ion batteries in the battery bank and presenting it as one Li-ion battery on the CAN bus.
- Programmable power down on user adjustable Li-ion battery (bank) SoC level.
- Programmable Auto-On function.
- Up to sixteen Li-ion batteries can be connected to the BCI Master side CAN bus without the need of external CAN power (Super B Li-ion batteries need power on their CANOpen Interface).
- Up to 100 Li-ion batteries can be connected to the BCI with use of external CAN power.
- Drive a Pre-charge contactor to switch a capacitive load and prevent inrush currents.
- A mechanism that allows temporary reconnection of the Li-ion battery bank to the DC-bus in an undervoltage situation.
- Logging function of diagnostics.
- Complete power down in case of an undervoltage of the Li-ion battery bank ($I < 1 \mu A$).
- The BCI has an open collector output/input for various additional applications.
- The BCI is a standalone device.
- The BCI must be configured using a CAN-USB (see Table 11) converter and the Be in Charge software.
- Three status LEDs to indicate the status of the BCI and the Li-ion battery bank.
- Two power supply inputs
 1. To power the BCI from an external supply or supply from the DC bus.
 2. To power the BCI from the battery bank, this power input has a self-disconnect feature.
- Two CAN communication ports
 1. The master port indicated by J1. This port is dedicated for the Li-ion batteries. The communication protocol is CANOpen.
 2. The slave port indicated by J2. This port is to communicate with an external network. It can also be used for other CAN protocols.

All the Li-ion battery (bank) values can be monitored on both ports. The Li-ion battery bank can also be controlled by both ports. If the slave port (J2) is used for another protocol than



CANopen, monitoring and control of the Li-ion battery bank using the Be in Charge software can only be done on the master port (J1). Though controlling on both sides is possible, changes are not forwarded to the other port. Hence, this is not advisable.

3.3. BCI functional behaviour

3.3.1. General

The BCI monitors all connected Li-ion batteries through the CAN bus. Whenever one or more Li-ion batteries reports an alarm, or is missing on the bus, the BCI will drive the contactors to disconnect the Li-ion battery (bank) from the DC bus to avoid misuse of the Li-ion battery or to prevent an unsafe situation. The alarms from the Li-ion battery can differ with each battery type. Because the alarm is indicated to the BCI as a general alarm, any Super B Li-ion battery with CANopen communication can be used in combination with the BCI. For alarms detected and signaled by the Li-ion battery consult the manual of the Li-ion battery.

3.3.2. Functionality of the power inputs

The BCI can be powered by an external power supply or, by the Li-ion battery bank. However, when powered from the Li-ion battery bank, the maximum number of Li-ion batteries in series is limited to four.

 **Caution!** The BCI can only be powered by a Li-ion battery bank if the bank consist of 4 or less Li-ion batteries in series.

The BCI has two supply and one GND/minus input, see chapter 4.5:

1. The battery supply input, J4 pin 9
2. The DC-bus / external supply input, J4 pin 10
3. GND/minus, J4 pin 1

The DC-bus / external supply input can be used if the Li-ion battery bank consists of more than 4 Li-ion batteries in series or when the self-shutdown functionality is not used. In that case the Li-ion battery supply input is not to be connected.

The Li-ion battery supply input has internal disconnect functionality to minimize self-consumption in case of a shut down. If the Li-ion battery bank is drained and there is a risk of damaging the Li-ion batteries, the BCI disconnects the Li-ion battery bank from the DC-bus and shuts down itself to no longer drain the Li-ion batteries. Refer to Figure 2 and Figure 3 simplified connection diagrams, depicted with focus on how to supply the BCI.

Only when the BCI is powered from the Li-ion battery bank the self-shutdown functionality is used. For this functionality, refer to chapter 5.6.

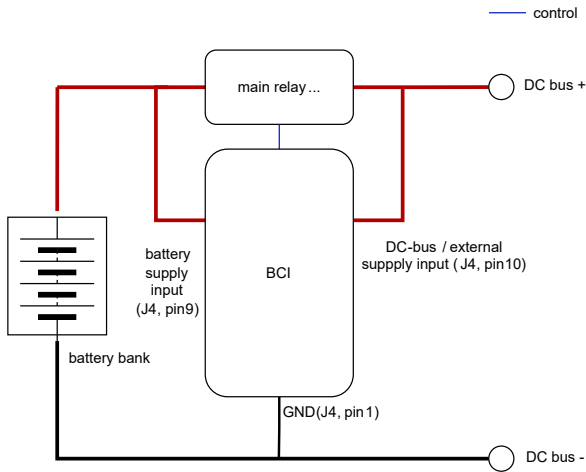

Figure 2. BCI supplied by the Li-ion battery bank

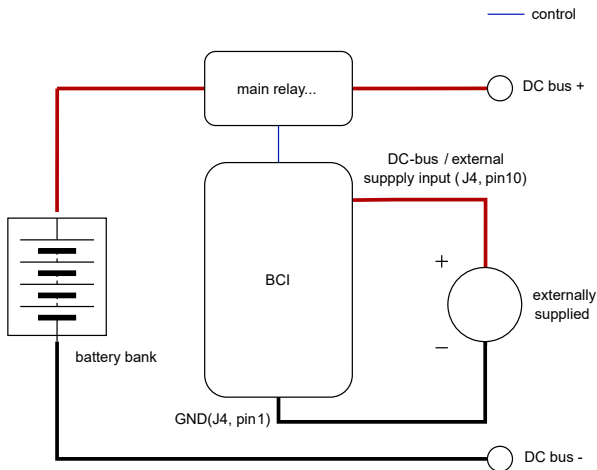

Figure 3. BCI supplied by external power supply

⚠ Caution! If Li-ion battery banks with a setup depicted in figure 2 are put in parallel by connecting the DC-bus, the self-shutdown functionality will only occur when all BCI's power is off. Until that happens the BCI will be fed by the DC-bus and is not able to self-shutdown.

3.3.3. BCI States

The BCI different states, are listed in Table 2 BCI states below:

| State | Main relay | Pre-charge relay | Description |
|---------------------|------------|------------------|---|
| ON | On | Off | Bank is connected to the DC-bus |
| OFF | Off | Off | Bank is disconnected from the DC-bus |
| Pre-charge | Off | On | Bank is pre-charging the DC-bus |
| Alarm | Off | Off | An error occurred |
| Shutdown | Off | Off | BCI is in power down mode |
| Undervoltage reboot | On | Off | BCI is turned on again after an undervoltage shutdown |

Table 2. BCI States

3.3.3.1 ON state

The BCI is in or can be set to the ON state when there are no active errors. In this state the BCI enables the main contactor(s), the Li-ion battery bank is connected to the DC bus. The BCI can be set to ON state using the Be in Charge software, or automatically when the Auto-On feature is enabled. The BCI can only reach the ON state via the Pre-charge state first.

3.3.3.2 OFF state

In this state the BCI disables all contactors, the Li-ion battery bank is disconnected from the DC bus. The BCI boots in the OFF state. In addition, the BCI can be set in OFF state manually by the Be in Charge software.

3.3.3.3 Pre-charge state

A contactor that must switch a large capacitive load can be exposed to high electric current during initial turn-on. This current, if not limited, can cause considerable stress or damage to the system components. Pre-charging is implemented to increase the lifespan of electronic components and increase reliability of the contactor. In the pre-charge state the main relay is disabled and the pre-charge relay is enabled. Refer to paragraphs 3.3.4.2 and 3.3.4.3 for details about the behavior on voltage dependent or time dependent pre-charge settings.

3.3.3.4 Alarm state

When the BCI is in alarm the following may have occurred:

- The number of Li-ion batteries that respond to a present request does not match the number of Li-ion batteries configured in the BCI. If the error is not resolved within 20 seconds, the BCI goes to OFF state.
- One or more of the Li-ion batteries reports an alarm. When the alarm of the Li-ion battery is cleared the BCI stays in OFF state. Depending on which type of alarm the Li-ion battery signaled, this alarm can be

cleared automatically. Refer to the battery manual for the type of alarm and how to resolve it.

If the alarm state is cleared and the Auto-On feature is enabled, the BCI can go back to the ON state.

3.3.3.5 Undervoltage off state - BCI externally powered

In case of an undervoltage event when the BCI is powered by an external power supply, it will go into OFF state instead of shutdown. The rest of the behavior as described for systems below 60 Vdc remains the same (see 5.4.1.4).

The BCI can be turned on again by power-cycling it (removing the power supply and powering it gain) or by forcing the relay ON via software or by reset. When this happens, the BCI will go into the undervoltage reboot state.

3.3.3.6. Undervoltage reboot state - BCI externally powered

In the undervoltage reboot state the Li-ion battery (bank) will be connected to the DC-bus, but discharging is limited regarding capacity to 0.1 Ah. This allows chargers that need to see a battery voltage, to start charging. The BCI will now allow the Li-ion battery bank to be discharged with 0.1 Ah before it will go to OFF state again. When the Li-ion battery bank is charged with 1 Ah, the BCI will switch to the ON state. The BCI will also go to the OFF state after 10 minutes spent in the undervoltage reboot state, which implies that the Li-ion battery bank should be charged with at least 1 Ah to avoid unnecessary shutdown.

3.3.3.7. Shutdown state - BCI battery bank powered

In this state the main relays and the pre-charge relay are disabled, the BCI doesn't take any power from the Li-ion battery bank and will turn off. However, if there is power on the DC bus the BCI will stay on and takes only power from the DC-bus.

3.3.3.8. Undervoltage Shutdown - BCI battery bank powered

When a Li-ion battery indicates an undervoltage, the BCI will go into the shutdown state to prevent draining the Li-ion batteries further. The BCI can be turned on again by a power cycle or by applying voltage on the load side (i.e. turning on a charger). When this happens, the BCI will go into the undervoltage reboot state.

3.3.3.9. Undervoltage reboot state - BCI battery bank powered

In the undervoltage reboot state the Li-ion battery (bank) will be connected to the DC-bus, but discharging is limited regarding capacity to 0.1 Ah. This allows chargers that need to see a battery voltage, to start charging. The BCI will now allow Li-ion the battery bank to be discharged with 0.1 Ah before it will go to shutdown state again. When the Li-ion battery bank

is charged with 1 Ah the BCI will switch to the ON state. The BCI will also go to the shutdown state after 10 minutes spend in the undervoltage reboot state, which implies that the Li-ion battery bank should be charged with at least 1 Ah to avoid unnecessary shutdown.

The BCI behavior during undervoltage shutdown is different from other error states. This was implemented specifically to prevent draining of the Li-ion battery bank and allow the automatic recovery as soon as a charger is connected. Refer to paragraph 5.4.1.4 (systems $\leq 60\text{Vdc}$) and paragraph 5.4.2.4 (systems $> 60\text{Vdc}$) for details about undervoltage behavior of the BCI.

⚠ Caution! In case of an undervoltage shutdown, charge the Li-ion batteries immediately.

⚠ Warning! In the case where a load and a charger are used simultaneously, and the charger cannot supply enough current for the load, the Li-ion batteries will be discharged. When the Li-ion batteries are empty the BCI wants to shut down due to an undervoltage event, but it can't since its powered by the charger on the load side of the BCI.

In this situation the BCI will remain in this state (relays off, but BCI on) if it is powered from the load side by the charger. It is not possible to charge the Li-ion batteries.

To resolve this situation all loads and the charger should be shut down, this will shut down the BCI. And then the charger should be turned on again, allowing the BCI to reboot. Now the Li-ion batteries can be charged. In case of parallel Li-ion battery banks, all other BCI's must first be off.

3.3.4. Driver behaviour

The BCI can control 2 protection contactors and a pre-charge relay:

- Main High Side (+)
- Main Low Side (-)
- Pre-charge

3.3.4.1. Turn on driver behaviour

When the BCI is set to ON state the drivers turn on in a certain sequence which is depicted in Figure 4.

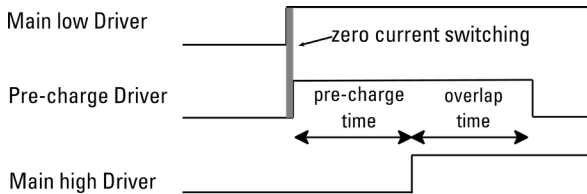

Figure 4. Turn-on sequence of drivers

When the system switches ON, the main low side driver and pre-charge driver are active immediately. The main high side driver will be active only after the pre-charge sequence is completed. See following paragraphs for Pre-charge behavior.

For systems $\leq 60\text{Vdc}$, typically only the Main High Side contactor is used.

3.3.4.2. Pre-charge driver behaviour - BCI battery bank powered

To minimize the inrush current, the main high side contactor will only be closed if the voltage difference measured over this contactor is less than $1.25\text{V} \times [\text{number of Li-ion batteries in series}]$. An external pre-charge contactor should be connected to Pin 3 and 4 of connector J4 (see Figure 11). For example, for a 48V system (4 Li-ion batteries in series) the voltage across the relay should be less than 5V. The BCI will remain in overlap state 1 seconds after the main contactor has been enabled.

3.3.4.3. Pre-charge driver behaviour - BCI externally powered

For limiting the inrush current for systems $> 60\text{Vdc}$ an external pre-charge relay should be connected to Pin 3 and 4 of connector J4 (see Figure 12).

However, the switching behavior is different, and solely depends on time, because the voltage difference over the contactor cannot be measured by the BCI. With the Be in Charge software it is possible for the user to select a pre-charge duration > 3 seconds. By default, it is set to 3 seconds.

The value of the pre-charge resistance and power rating is best calculated based on the knowledge of the capacitive load of the system.

3.3.4.4. Turn off behaviour

When the BCI is set to OFF state, all drivers become inactive immediately.

3.4. BCI control functions

3.4.1. Auto-on

The Auto-On function automatically sets the BCI into ON state when the BCI is powered up. Also, if a battery alarm has occurred and this alarm is cleared (see 3.4.3.4), the BCI automatically goes to the ON state if the auto-on function is enabled. The Be in Charge software can be used to control the auto-on function refer to 6.3.6. This functionality only works with at most 4 Li-ion batteries in-series.

3.4.2. SoC shutdown/Switch-OFF

The SoC switch-OFF is a function that makes it possible, at a certain level of state of charge, to put the BCI in:

- Shutdown state: if the BCI is powered by the Li-ion batteries,
- OFF state: if the BCI is powered by an external power supply.

The level can be set by the user and this function can be enabled or disabled. By default, it is disabled. Control of this function is done by the Be in Charge software see 6.3.7.

When Li-ion the battery bank reaches the SoC set level, the BCI will go into shutdown or OFF state. It is activated only with descending SoC level. If the BCI is in SoC shutdown/OFF state it can be turned on again by power-cycling it. When the BCI is turned on again, it's in the SoC recovery state, during which it will not shutdown on SoC again unless the SoC of the Li-ion battery (bank) is charged 1% above the set level. This re-enables the functionality. Once the SoC shut down/off state has occurred and the BCI is turned on again, the Li-ion battery bank can be discharged further until an undervoltage occurs.

The BCI will report a warning that the SoC is running low when the reported SoC is within 10% over the set shut down level.

Note: It is possible – with BCI software version 2.35 or higher and the latest Be in Charge software - to configure the BCI to display and use the average SoC of the bank vs the lowest. Super B recommends using the lowest.

3.4.3. Reset

Even with Auto-On enabled, some alarm types of the Li-ion battery can only be cleared by a reset. To perform a reset, the user can select either to add an external hardwired reset button on the BCI inputs (J3 pins 3-4, see 5.6.3) or reset by CANopen with use of the the Be in Charge software.

4. General product specifications

| | |
|----------------------|---------------------------------|
| Product name: | BCI |
| Product designation: | 2CAN/115/80/29 |
| Producer: | Super B |
| Product type: | Battery Communication Interface |
| Product Lifespan: | >10 years |

Table 3. General product specifications

4.1. Electrical specifications

| Description | Value | Unit |
|--|-----------|------|
| Power supply | 7.5...60 | Vdc |
| Power supply required if BCI is powering the CAN bus | 15...60 | Vdc |
| Power draw excluding CAN power | <1 | W |
| Current draw "full shut down" | <1 | μW |
| Internal Relay switch current (max, all 4) | 4 | A |
| Internal Relay switch voltage (max, all 4) | 60 | Vdc |
| Internal Relay isolation voltage | 60 | Vdc |
| Input voltage for manual control inputs | 0...60 | Vdc |
| Input high level | 6.4...6.8 | Vdc |
| Input isolation voltage | 60 | Vdc |
| Generic IO open drain, referring to BCI ground | 60 | Vdc |
| | 100 | mA |

Table 4. Electrical specifications

4.2. Mechanical specifications

| | |
|---------------|-------------------|
| Height (H) | 28.5 / 29.5 mm |
| Width (W) | 114.5 / 115.5 mm |
| Thickness (T) | 79.5 / 80.5mm |
| Weight | 136g ± 10 g |
| Case material | PC / ABS (FR3010) |

Table 5. Mechanical specifications

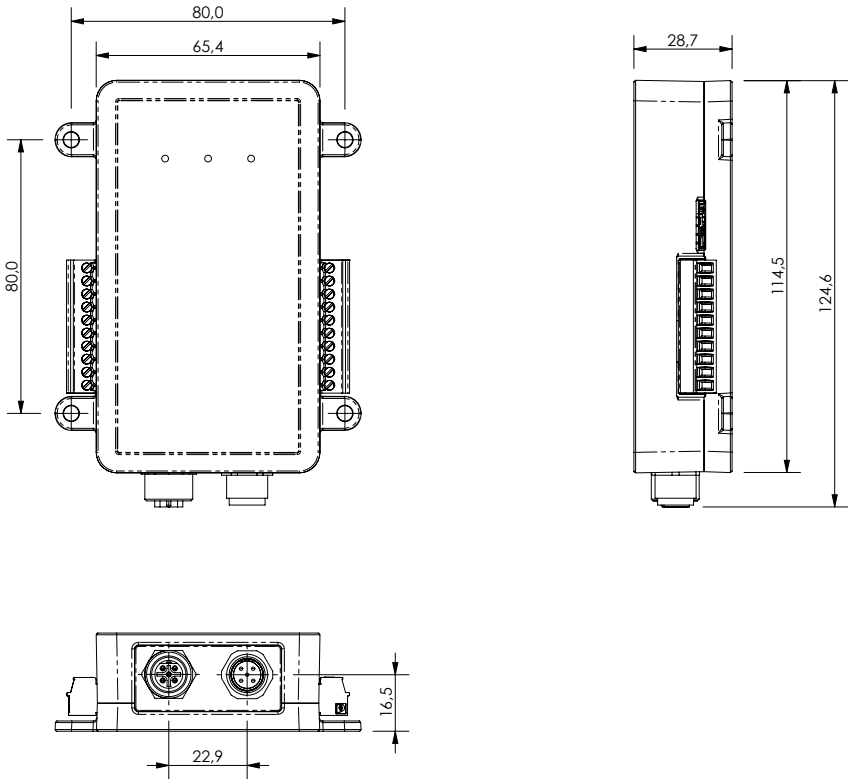

Figure 5. Dimensions

4.3. Environmental specifications

| | |
|---------------------------------------|--------------------------------------|
| Operating temperature range | -40°C to 85°C / -40°F to 185°F |
| Recommended storage temperature range | -40°C to 85°C / -40°F to 185°F |
| Relative humidity | 5-85%, non-condensing |
| Ingress protection | IP20 |
| Shock and vibration | Tested according to DNV requirements |

Table 6. Environmental specifications

⚠ Warning! The BCI may only be used in conditions specified in this manual. Exposing the BCI to conditions outside the specified boundaries may lead to serious damage to the product and/or the user.

4.4. Scope of delivery

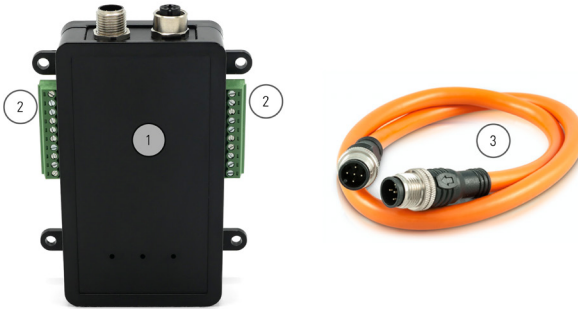

Figure 6. Scope of delivery.

1. (1x) Battery Interface Box
2. (2x) Phoenix plug 10 MC 1,5/10-STF-3,81 1827787
3. (3x) CAN Cable male to male 0.6m

4.5. Connections, indicators and controls

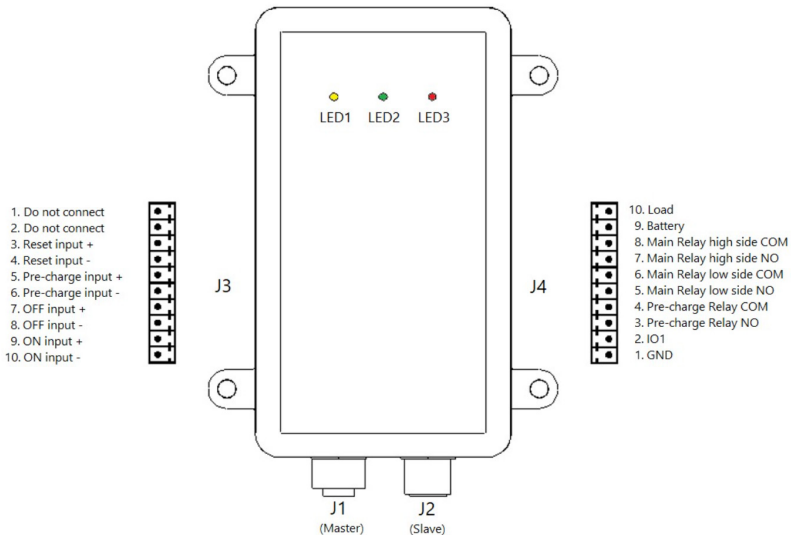

Figure 7. Connections, Indicators and controls

2. J1, CAN Master connector; 5-pin CANopen micro style connector female
3. J2, CAN Slave connector; 5-pin CANopen micro style connector male
4. J3, I/O Connector, 10 pole; Phoenix MPE030-38110
5. J4, I/O Connector, 10 pole; Phoenix MPE030-38110
6. LED 1 - Yellow
7. LED 2 - Green
8. LED 3 - Red

4.5.1. CAN connector pinout (Master/Slave)

| PIN # | Signal | Master side | Slave side |
|-------|----------|--------------------------------|--------------------------------|
| 1 | CAN_SHLD | Optional CAN Shield | Optional CAN Shield |
| 2 | CAN_V+ | CAN bus supply voltage 12V | Not connected |
| 3 | CAN_GND | Ground / OV | Ground / OV |
| 4 | CAN_H | CAN_H bus line (dominant high) | CAN_H bus line (dominant high) |
| 5 | CAN_L | CAN_L bus line (dominant low) | CAN_L bus line (dominant low) |

Table 7. CAN connector pinout

Male

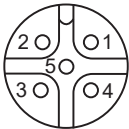

Female

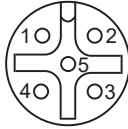

Figure 8. CAN Connections Male and Female

4.5.2. J3 (I/O Connection 10)

| PIN | Description |
|-----|--------------------|
| 1 | Not used |
| 2 | Not used |
| 3 | Reset input + |
| 4 | Reset input - |
| 5 | Pre-charge input + |
| 6 | Pre-charge input - |

| | |
|----|----------------------------------|
| 7 | Main Relay/Contactor Off input + |
| 8 | Main Relay/Contactor Off input - |
| 9 | Main Relay/Contactor On input + |
| 10 | Main Relay/Contactor On input - |

Table 8. J3 (I/O Connection 10)

4.5.3. J4 (I/O Connection 10)

| PIN | Description |
|-----|------------------------------|
| 1 | GND |
| 2 | IO1 |
| 3 | Pre-charge relay NO |
| 4 | Pre-charge relay common |
| 5 | Main relay, low side NO |
| 6 | Main relay, low side common |
| 7 | Main relay, high side NO |
| 8 | Main relay, high side common |
| 9 | Battery + |
| 10 | Load + |

Table 9. J4 (I/O Connection 10)

4.5.4. Indicators

| LED 1 (Yellow) | LED 2 (Green) | LED 3 (Red) | Mode |
|----------------|---------------|-------------|--|
| Flashing | Off | Off | Pre-charge |
| Off | On | Off | Main relay On |
| On | On | Off | Main relay Off |
| On | On | On | Battery in error mode or communication error |
| Off | Flashing | Off | CAN network scanning |

Table 10. Indicators

4.6. Peripheral equipment

The BCI can be used in combination with several Super B products

| Article name | EAN code |
|---|---------------|
| Nomia 12V100Ah | 8718531360662 |
| Nomia 12V160Ah | 8718531360570 |
| Nomia 12V210Ah | 8718531361645 |
| Nomada 12V105Ah | 8718531361799 |
| Relay GX14BA 12V 350A | 8718531361157 |
| Relay GX14CA 24V 350A | 8718531361164 |
| Relay GX14FA 48V 350A | 8718531361171 |
| Relay GX16BE 12V 600A | 8718531361096 |
| Relay GX16CE 24V 600A | 8718531361102 |
| Relay GX16FE 48V 600A | 8718531361089 |
| Relay TBS RBS 12V500A | 8718531362031 |
| Relay TBS RBS 24V500A | 8718531362048 |
| Relay LIR250 12V/24V 500A | 8718531361126 |
| CAN Terminator Female Low Profile | 8718531362000 |
| CAN Terminator Male Low Profile | 8718531361997 |
| CAN Cable 0.6m Male to Female | 8718531360716 |
| CAN Cable 1m Male to Female | 8718531360723 |
| CAN Cable 2m Male to Female | 8718531360730 |
| CAN Cable 5m Male to Female | 8718531360747 |
| CAN Cable 10m Male to Female | 8718531360754 |
| CAN Cable 0.6m Female right angled to Male straight | 8718531361492 |
| CAN Splitter Male to 9x Female | 8718531361065 |
| CAN T-Splitter Male to Male + Female | 8718531360761 |
| CAN power cable 2m | 8718531360792 |
| CAN to USB Converter | 8718531361201 |
| Be in charge Monitoring Kit | 8718531362086 |

Table 11. Optional peripheral equipment

5. Installation

5.1. General information

- ⚠ **Warning!** Never install or use a damaged BCI.
- ⚠ **Caution!** Do not reverse connect the BCI.
- ⚠ **Caution!** Use the BCI within the specifications.

5.2. Unpacking

Check the BCI for damage after unpacking. If the BCI is damaged, contact your reseller or Super B. Do not install or use the BCI if it is damaged!

5.3. Required tools for installation

- Screwdriver flat 5 mm

5.4. Placement of the BCI

Before it is used, the BCI must be positioned in such a way that it will not move during use. The BCI may be fixed in place by using the mounting holes (Figure 9).

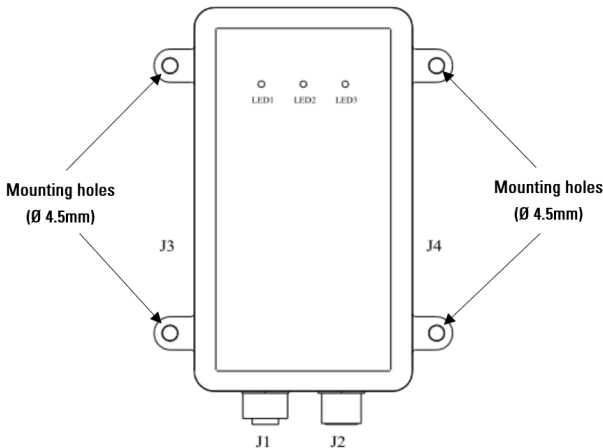

Figure 9. Mounting the BCI

5.5. Connection wires

Use appropriate wire for the connection wires to ensure no overheating or unnecessary losses occur. Consult the SAE-J378 or ISO 10133:2012 standards to determine the appropriate wire properties. Use appropriate fuses matching the wires and load.

5.6. Electrical installation

⚠ Caution! High voltages may be present in the Li-ion battery system. Access to the battery system is only allowed by trained professionals!

Safety components selection and design (fuses, cable thickness etc.) should be done following safety guidelines especially for systems > 120Vdc. Super B is not responsible of the overall system integration.

⚠ Warning! Always take safety precautions when working on battery systems.

In certain applications, the below components / functionalities might be necessary:

1. Ground Fault Detection device – required for ungrounded systems.
2. Emergency stop – depends on the user preference but can also be a safety requirement.
3. EMC Filter – the need should always be evaluated especially in installations which include high frequency drives.
4. Manual battery switch – is necessary during maintenance, to isolate the battery voltage from the rest of the system during human intervention.

If the BCI is used with a Li-ion battery bank that consists of 4 or less Li-ion batteries in series (48V or less) the battery supply power input of the BCI and its functionality can be used. If the BCI is used with a Li-ion battery bank with a higher voltage it needs to be powered by an external power supply. This supply can be between 15 and 60Vdc, typical 24 Vdc .

Note: For systems ≤ 60Vdc, Super B offers a complete solution: the Battery Interface Box (BIB).

The below will describe in detail the differences and show examples of complete installations for each of those systems.

5.6.1. Electrical installation - BCI power from battery bank

Figure 10 depicts a typical setup drawn of a 48 V or less Installation.

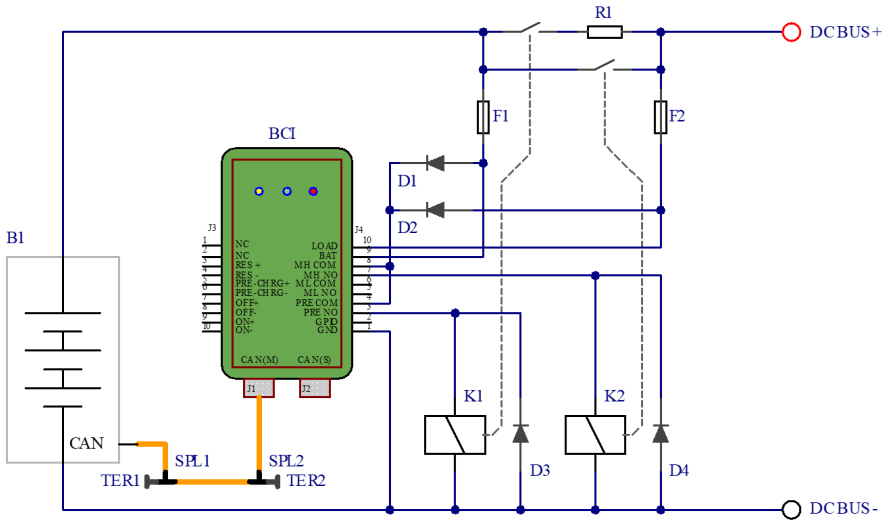

Figure 10. BCI powered from battery bank

Circuit description

The BCI is powered by the battery bank through the pin 1 (minus) and pins 9 & 10 (plus). If the main contactor is closed the BCI uses the power from pin 10, if the main contactor is open it uses power from the battery bank through pin 9. This is internally controlled by the BCI. The coils of contactors K1 and K2 are connected to the pre-charge driver and the main contactor high driver of the BCI. D3 and D4 are to absorb the back-EMF of the contactor coils. Some contactors have built-in back-EMF diodes or transient diodes. In that case it is advised not to install D3 and D4. D1 and D2 are needed to provide power for the contactor coils. Fuses F1 and F2 should be placed close to the main contactor's terminals. The pre-charge resistor should be tailored to the application. See 5.6.4 for calculating the pre-charge.

| Component | Specification | Remark |
|-----------|---------------|--------------------------------------|
| D1 | 100 V 3 A | |
| D2 | 100 V 3 A | |
| D3 | 100 V 3 A | might not be needed depends on relay |

| | | |
|----|------------|--------------------------------------|
| D4 | 100 V 3 A, | might not be needed depends on relay |
| F1 | 5A 100 V | |
| F2 | 5 A 100 V | |
| K1 | Na | Depends on application |
| K2 | | Depends on application |
| R1 | | Depends on application, see 5.6.4 |

Table 12. Circuit description

5.6.2. Electrical installation - BCI externally powered

Figure 13 depicts a typical setup drawn of an externally powered Installation usually higher than 48 V.

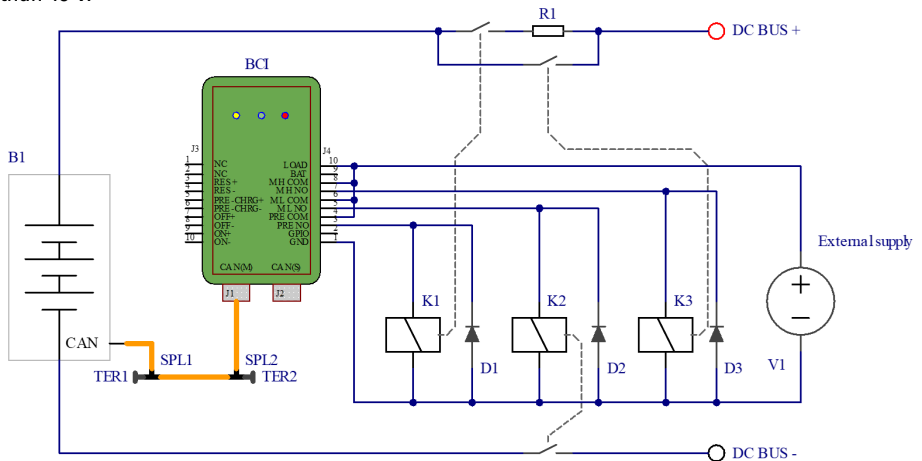

Figure 11. BCI externally powered

Circuit description

The BCI is powered by the external power supply, through pin 1 (minus) and pin 10 (plus). The coils of contactors K1, K2 and K3 are connected to the pre-charge driver, the main contactor low and the main contactor high drivers of the BCI. D1, D2 and D3 are to absorb the back-EMF of the contactor coils. Some contactors have built-in back-EMF diodes or transient diodes. In that case it is advised not to install D1, D2 and D3. The pre-charge resistor should be tailored to the application. See 5.6.4 for calculating the pre-charge.

| Component | Remark |
|-----------------|--|
| D1 | Depends on contactor |
| D2 | Depends on contactor |
| D3 | Depends on contactor |
| K1 | Depends on application |
| K2 | Depends on application |
| K3 | Depends on application |
| R1 | Depends on application, see 5.6.4 |
| | Depends on application |
| External supply | 24 V 1 A, power for the contactors should be added |

Table 13. Circuit description

5.6.3. Manual control

The BCI can be controlled manually with external hardwired control buttons. The manual inputs can be normally open contacts or normally closed contacts. A typical setup is depicted in Figure 12.

The manual inputs are default configured for “active high”, so normally open contacts can be used. This can be configured under Input level configuration, see chapter 6.3.3.

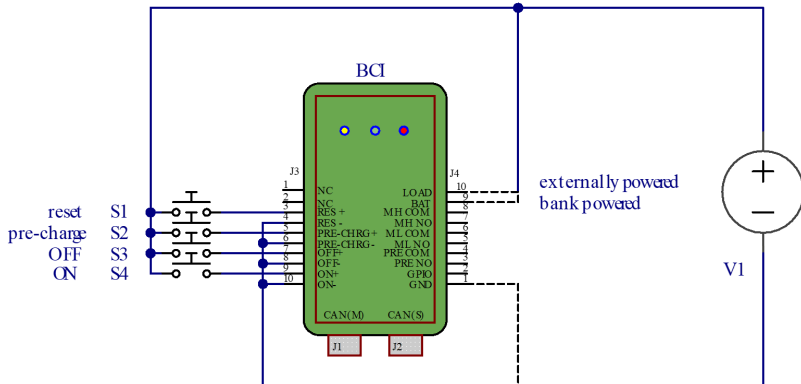

Figure 12. Manual control

Note: the off signal overrules the on and pre-charge signal.

5.6.4. Pre-charge selection

A contactor that must switch a large capacitive load can be exposed to high electric current during initial turn-on. This current, if not limited, can cause considerable stress or damage to the system components. Pre-charging is implemented to increase the lifespan of electronic components and increase reliability of the contactor. In the pre-charge state the main relay is disabled and the pre-charge relay is enabled. Refer to paragraphs 3.3.4.2 and 3.3.4.3 for details about the behavior.

When pre-charging a DC-bus, usually not only the capacitive load needs to be considered. Often the DC-bus has a more complex impedance and there is some resistive load that has to be taken into account choosing the pre-charge resistor.

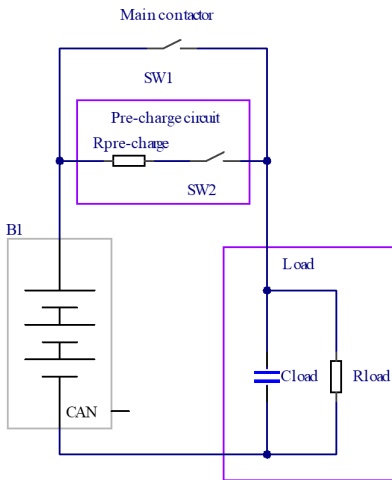

Figure 13. Simplified circuit

In Figure 13, a possible load configuration is depicted. The purpose of the pre-charge circuit is to charge the DC-bus so that the voltage across the main contactor is small enough to turn it on without damaging it. When the main contactor is about to close, the voltage across it must be less than:

Equation 1
$$U_{\text{contactor}} < I_{\text{make}} \cdot R_{\text{battery bank}}$$

This means that the value of the pre-charge resistor needs to be large enough to limit the maximum current (when the load is at 0 V):

$$\text{Equation 2} \quad R_{pre-charge} > \frac{U_{battery\ bank}}{I_{max\ pre-charge\ relay}} - R_{battery\ bank}$$

The maximum current is the limit in this equation, it is given for any of the components in the pre-charge path, such as the relay or the load itself.

If the load has a resistive impedance as well, the steady-state voltage won't become equal to the battery voltage. This means that the value of the pre-charge resistor needs to be low enough to make the voltage across the main contactor as low as stated in Equation 1. Which leads to the following:

$$\text{Equation 3} \quad R_{pre-charge} < R_{load} \frac{U_{contactor}}{U_{battery\ bank} - U_{contactor}}$$

Equation 2 and Equation 3 are the limits for selecting the resistance value of the pre-charge resistor.

Below an example of how to select a pre-charge resistor and set the pre-charge duration for a system consisting of 32 batteries in series:

Considering:

System voltage 460V (32 charged batteries in series, at end of charge voltage).

A capacitive load of 10mF.

A resistive load of 1 kOhm.

The maximum switching current of the contactor is 600A.

The battery bank total internal resistance is 160mΩ.

The maximum acceptable voltage difference across the contactor is 96V (600A x 160mΩ).

The pre-charge resistor must be smaller than: 263 Ohm. The closest standard value is 220 Ohm.

The inrush current is reduced significantly after approximately a time of $5 \times \tau$.

$$\tau = R \cdot C = \frac{1000 \cdot 220}{1000 + 220} \cdot 10mF = 1.8\ s$$

$$5 \times \tau = 9\ \text{seconds}$$

It is advised to set the pre-charge time to 10 seconds or more see 3.3.4.2.

The resistor needs to dissipate as much energy as the energy stored in the load's capacitors:

$$E = \frac{C \cdot V^2}{2} = \frac{10\ mF \cdot (460V)^2}{2} = 1058\ \text{Joules.}$$

$$P = \frac{E}{5 \cdot \tau} = \frac{1058\ J}{9\ s} = 117.5\ W$$

This power is dissipated for a relative short time. The pre-charge resistor must be chosen to be able to handle this power/ energy.

Note: If needed please contact Super B for selecting the ohmic value of the pre-charge circuit and the maximum current the pre-charge circuit can deliver.

Note: If the BCI is measuring the voltage across the contactor, it only activates the main contactor if the voltage difference is small enough. Refer to 3.3.4.3.

⚠ **Caution!** If the load draws more current than the pre-charge current, the BCI will not be able to engage the main relay, since it cannot properly pre-charge the system. It is important that the load is not engaged before the BCI is done pre-charging.

5.7. CAN Bus

5.7.1. General information

To use the BCI, the CAN Master bus needs to be connected to the Super B Li-Ion batteries. More information on the CANopen bus can be found at the CiA website: www.can-cia.org. The required documentation can be found in the following CiA documents: (or in a future version of these documents.)

- CiA 301
- CiA 303_1 V1.8.0; Sections 5 (AC and DC parameters) and 7.2: (5-pin “micro” style connector)

5.7.2. Connecting the CAN network cables

The Li-ion batteries should be connected to the BCI via the CAN interface. Start creating the CAN bus connection as shown in Figure 14.

The BCI must be connected to the male-to-male cable to the first splitter and from there the rest of the battery bank can be connected. For further information about the CAN network, read the manual of the batteries that will be connected to the BCI.

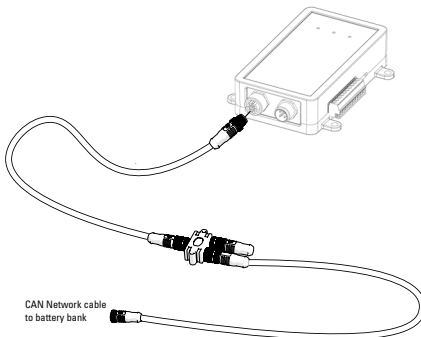

Figure 14. CAN Connection J1 to BCI

5.7.3. CAN Bus network topology

The CAN Bus must be used in a bus network topology. Do not use a ring- or a star topology. The maximum CAN bus length is limited. All Super B Li-ion batteries have a factory default bitrate of 250kbps

| Bit rate | Bus length (L) | Max. stub length (S) | Accumulated stub length |
|----------|----------------|----------------------|-------------------------|
| 250 kbps | 250 m | 11 m | 55 m |

Table 14. CAN bus speed

A high-speed bus requires termination at the two ends of the bus

5.7.4. Termination Resistors

Use termination resistors at the end nodes to prevent reflections on the line. The value of this resistor should be +/- 120Ω. More information on termination resistors can be found in CiA document 303_1 V1.8.0, section 5.

5.7.5. CAN bus power

Due to the galvanic isolation the CAN interface of the Li-ion batteries needs power. The BCI can provide this on the CAN master bus. This can be done up to 16 Li-ion batteries. If more Li-ion batteries are connected the CAN bus must be powered externally, using a CAN power cable.

The CAN bus power should be at least 10V and should not exceed 30V! Therefore, in any 12V or 24V system the CAN bus can be powered directly by the system power.

A 12V system always needs an additional CAN power cable.

The CAN slave bus is not powered by the BCI!

There are multiple possible ways to connect the CAN power cable to the BCI and Li-ion batteries:

1. The first option is to connect the (+) terminal (red wire) of the CAN power cable to the load side of the main relay. There is a disadvantage to this setup; when the main relay opens the CAN power is cut-off. This causes the loss of CAN communication between the Li-ion batteries and the BIB. The load side of the BIB must be powered to have CAN communication while the main relay is OFF. Without CAN communication the BIB cannot turn on.
2. The second option is to connect the (+) terminal of the CAN power cable to the batteries side of

the main relay. In this case the CAN communication is always available. There is a disadvantage to this setup; the CAN bus is always powered, therefore; it will drain the Li-ion batteries slightly even when the main relay is turned off (the draining current depends on the amount and type of batteries connected to the CAN bus). When using this setup, Li-ion batteries can be deeply discharged. Make sure that the Li-ion batteries will be charged immediately when they are empty.

5.7.6. Integrating CAN Protocol

For integrating the Super B CAN protocol please contact your Super B sales representative or Super B application engineering.

5.7.7. General purpose I/O

The BCI has an output function that as of software version 2.36 provides a signal for chargers. It can only be used in combination with Li-ion batteries that support this feature also. Contact Super B for the right software version.

This mechanism controls chargers by using the pin IO1 to allow to charge if it is pulled low by the BCI. The BCI will inquire the Li-ion batteries if charging is allowed. This function does not control the state of the BCI (like ON state or OFF state) should charging not be allowed, it only signals towards the charger. Refer to 4.1 or the electrical specification.

| | |
|------------|-----|
| Pin 1 (J4) | GND |
| Pin 2 (J4) | IO1 |

Table 15. General purposed I/O

6. BCI use

6.1. General information

- ⚠ Caution!** In case of an undervoltage shutdown, charge immediately.
- ⚠ Warning!** Follow the safety guidelines and measures of chapter 1.

If a preconfigured BCI has been ordered at Super B, the steps in chapter 6.2 are not necessary. If this is not the case, configuring can be done as described in chapter 6.2.

All the battery (bank) values can be monitored on both BCI ports. The battery bank can also be controlled via both ports. If the slave port (J2) is used for another protocol than CANopen, monitoring and control of the battery bank using the Be in Charge software can only be done on the master port (J1).

6.2. Configuring the BCI and the battery bank

Before the BCI and battery bank can be used, the BCI needs to be configured and the batteries need to have a unique battery node ID. Configuring the BCI and the batteries can be done by using the Super B Be in Charge Software.

For connecting the BCI to a computer, a CAN to USB converter is required, see table 12. Refer to Figure 15 for connecting the CAN to USB converter to the BCI.

6.3. Battery ID's

In multi-battery systems, each battery shall have a unique Node ID number. The default Node ID for a Super B Li-ion battery is 10. This number shall be changed depending on the configuration. If a complete system has been ordered at Super B, the Li-ion batteries will have been preconfigured and renumbering is not necessary. If this is not the case, renumbering can be done manually.

Any Node ID number between 2 and 100 can be assigned to a Li-ion battery. Node ID 1 should not be used for Li-ion batteries as it is reserved for the BCI. We recommend not to use Node ID 10 for multi battery configurations as it may be confusing in case a Li-ion battery is added to the system.

Multiple Li-ion batteries with the same number will result in unpredictable behavior of the system.

It is recommended to label the Li-ion batteries with their assigned node ID. Try to number the Li-ion batteries in such a way that the battery bank configuration (number in parallel, number in series) can be easily recognized. For example, in a 4 series 2 parallel system use node ID 11, 12, 13, 14 for the four Li-ion batteries in series and node ID 21, 22, 23, 24 for the other four Li-ion batteries in series.

6.3.1. Battery ID renumbering procedure

Use the following procedure to renumber the node ID for each battery in the system.

1. Connect one Li-ion battery to the CAN Master bus (see figure 15).

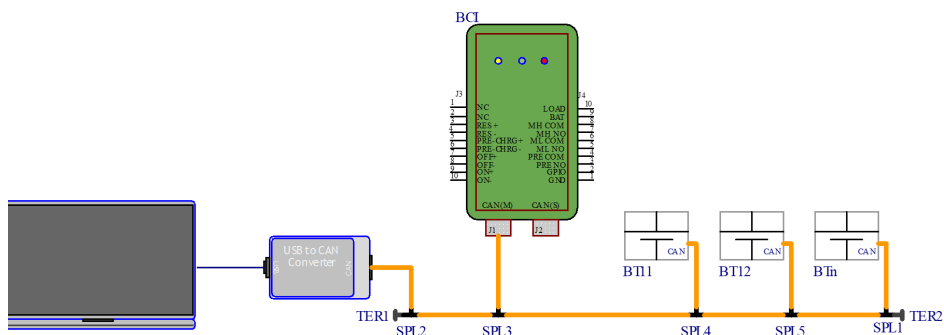

Figure 15. Renumber battery 1

2. Select the 'Scan' button to start scanning for devices. You can also select the scan/refresh icon in the top-left corner (Figure 16).

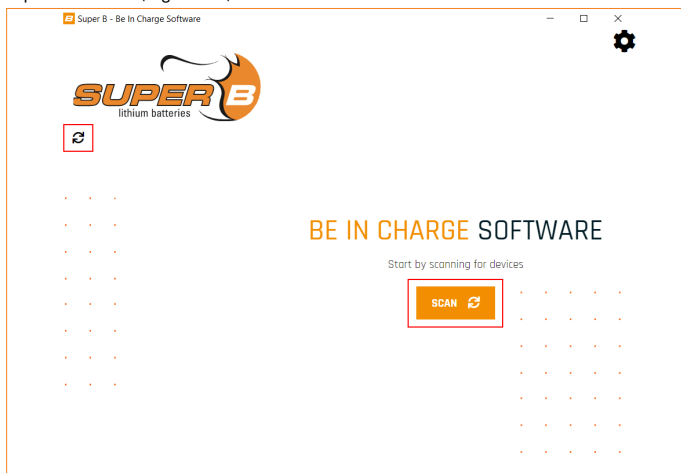

Figure 16. 'Scan' for devices

3. In order to make changes to battery node ID it is necessary to set the user level to 'Expert User' (Figure 17 and 18).

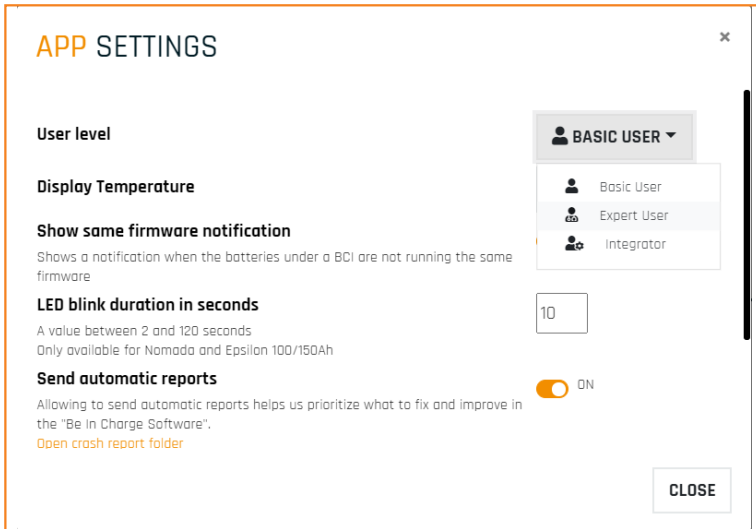

Figure 17. Set user level to 'Expert user'

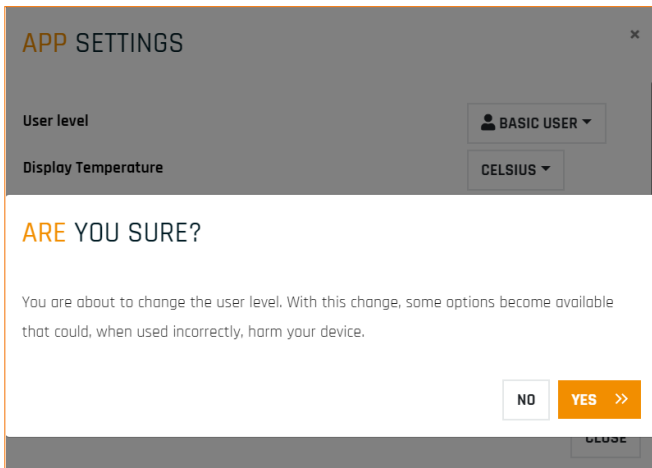

Figure 18. Confirm user level change

4. Navigate to the 'Details' page and make sure to change the battery node ID of the first battery to 11 (Figure 19 and 20)

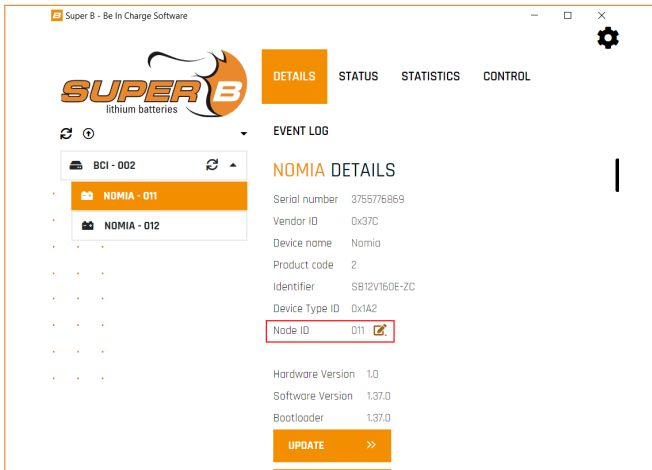

Figure 19. Change the battery 'Node ID' of the first Li-ion battery

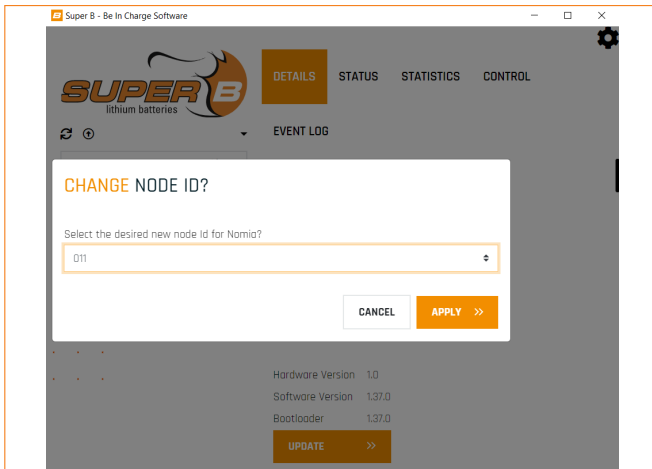

Figure 20. Select the desired new node ID from the dropdown menu

5. Verify if the correct number is assigned to the Li-ion battery by selecting the scan/refresh icon on the top-left corner.
6. Connect the next Li-ion battery and repeat step 4 and 5 until all Li-ion batteries have been assigned a unique Node ID.
7. Continue with the battery layout

6.3.2. Battery layout

The BCI represents a battery bank as one battery. To be able to do so, the BCI must be informed about the layout of the batteries. This means configuration has to be done to “tell” the BCI how the batteries are connected (parallel and/or series). The number of batteries that are connected is detected by the BCI itself by doing a full scan. If the BCI is not configured by Super B the end user must follow the procedure below to set the battery layout.

1. Connect all Li-ion batteries to the BCI via the CAN connection as described in chapter 5.7.2.
2. Perform a scan by selecting the scan button or refresh icon on the top-left corner.
The Be in Charge software request the BCI to scan for connected Li-ion batteries. When the scan is completed, the number of Li-ion batteries connected will be shown in the “configuration tab” in the “Total # batteries” field (see Figure 21)
3. Configure the battery bank with the slide bar in the “#Batteries in series” and “#Batteries parallel” fields. The amount of Li-ion batteries in series multiplied by the amount of Li-ion batteries in parallel should be equal to the total amount of Li-ion batteries. The Be in Charge software will not allow an invalid configuration.

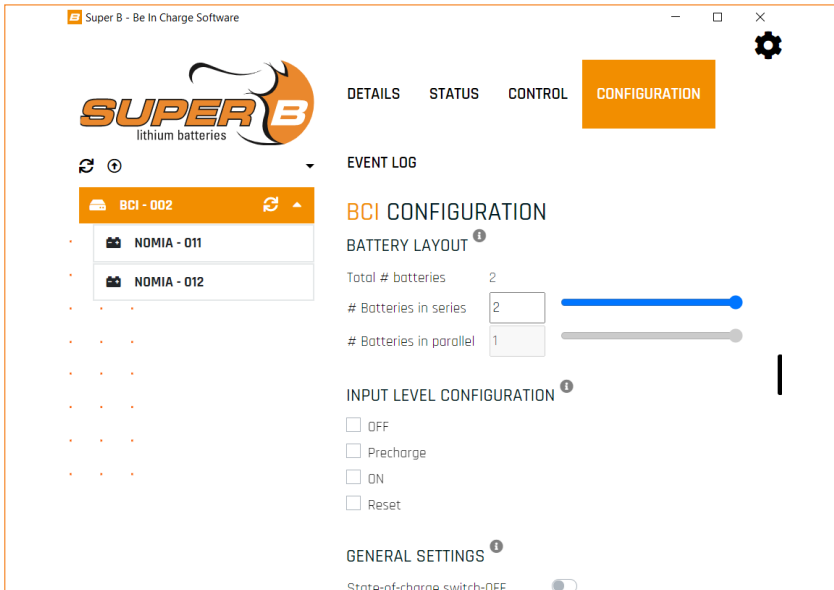

Figure 21. Be in Charge Software - configuration tab

6.3.3. Input level configuration

The BCI contains four hardware inputs: Reset, Pre-charge, OFF and ON (see Figure 22). The inputs can be used to control the BCI. With the “Input level configuration” box you can select whether the inputs should be active high or active low.

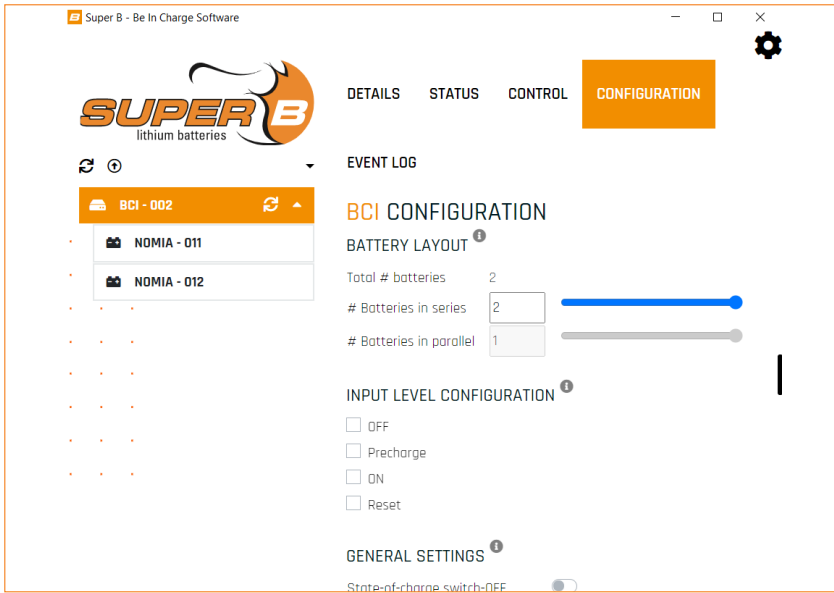

Figure 22. Be in Charge Software - Input level configuration

6.3.4. BCI Modules

The BCI Modules (see Figure 23) can be used to select the communication protocol. The default setting is CANOpen (CiA418 and Super B features). There is also an option to use proprietary protocols. This list is subject to change therefore, the list may look differently depending on the software version.

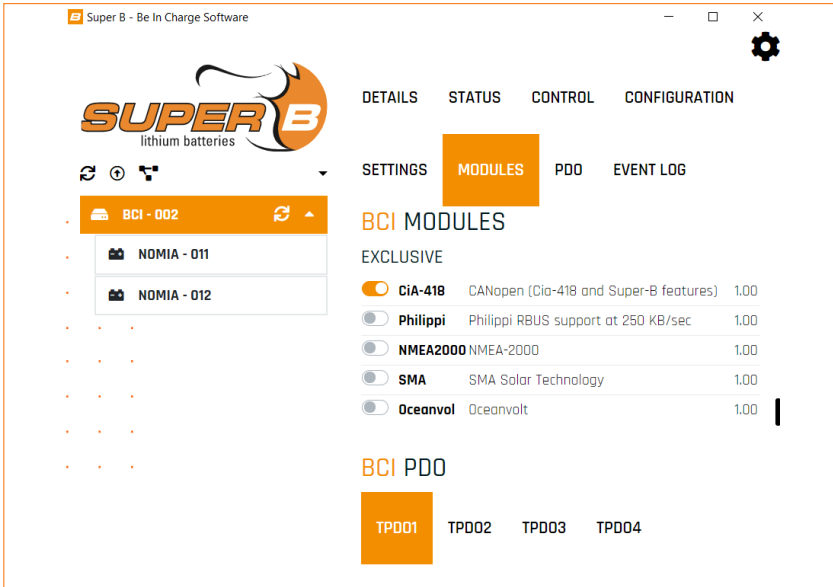

Figure 23. BCI Modules and communication protocol

6.3.5. Pre-charge adjustment

When the BCI is powered externally (paragraph 5.6.2), it is possible to adjust the pre-charge duration in the below section (see Figure 24). This can only be adjusted when “External power” is enabled.

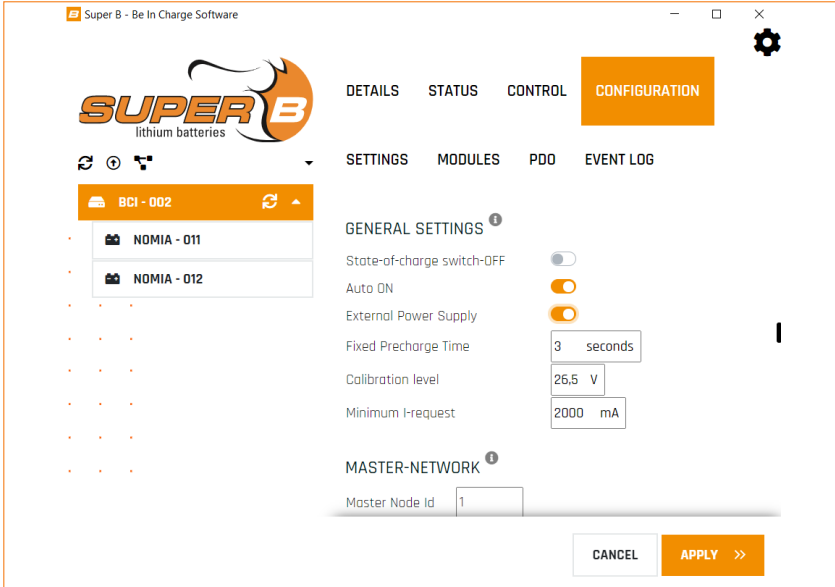

Figure 24. BCI Precharge time

6.3.6. General settings: Automatic control

The Auto On enables the automatic start up option (chapter 3.4.1). The main relay(s) will be engaged automatically when the BCI starts up or all the alarms are cleared, see Figure 25. When Auto On is disabled the Control buttons in the control tab or the external control inputs can be used.

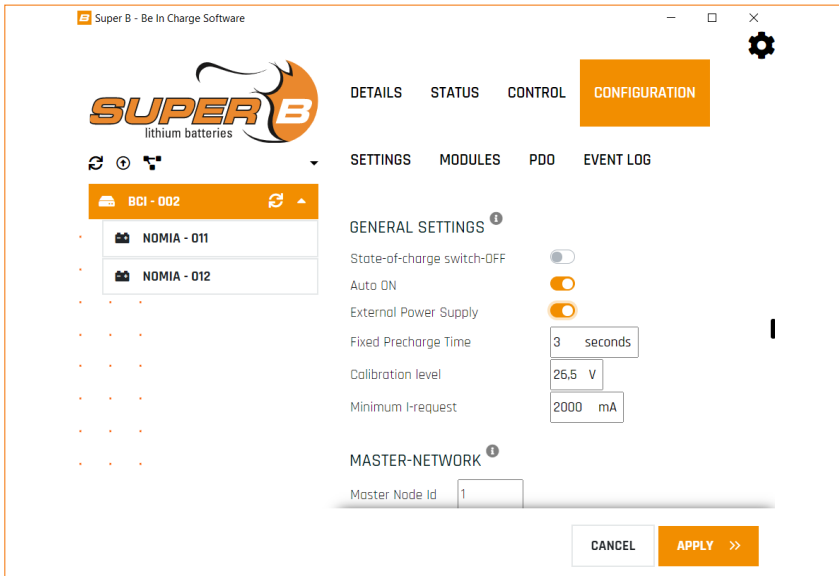

Figure 25. Auto-ON

6.3.7. General settings: State-of-charge switch-OFF level

The State of charge switch off level is a function that makes it possible to put the BIB in shutdown state (see 3.4.2) at a certain level of state of charge. This level can be set by the user (see Figure 26). By default this function is disabled.

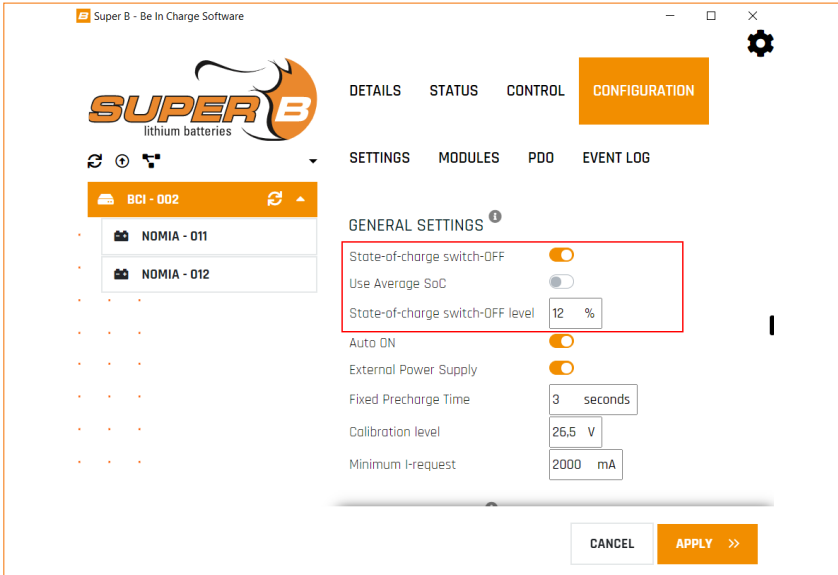

Figure 26. SoC switch OFF level

6.3.8. Saving a configuration

To save a configuration select the “Apply” button on the bottom-right corner (see Figure 27).

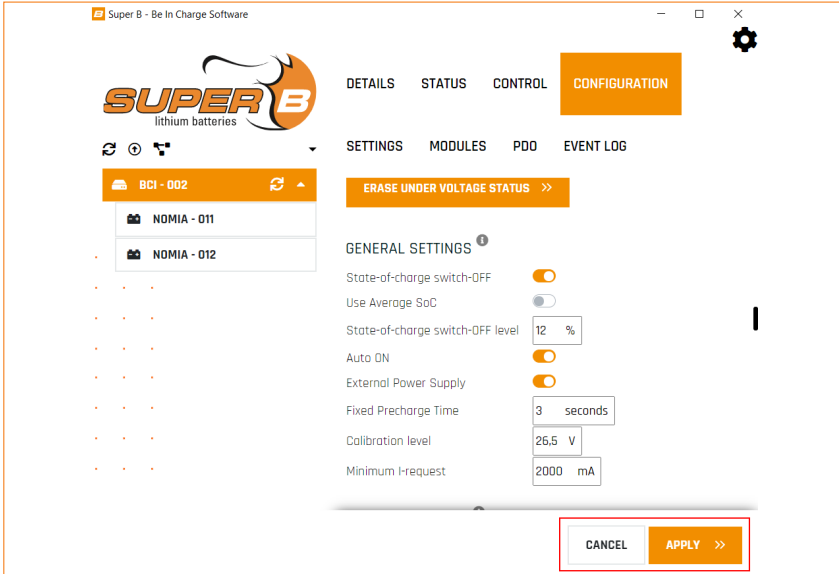

Figure 27. Saving a configuration

6.4. Status and control

The state of the BCI can be controlled by the Be in Charge software. The Be in Charge software can read and set the state of the BCI. The state in which the BCI is, is indicated by the indication bar as depicted in Figure 28.

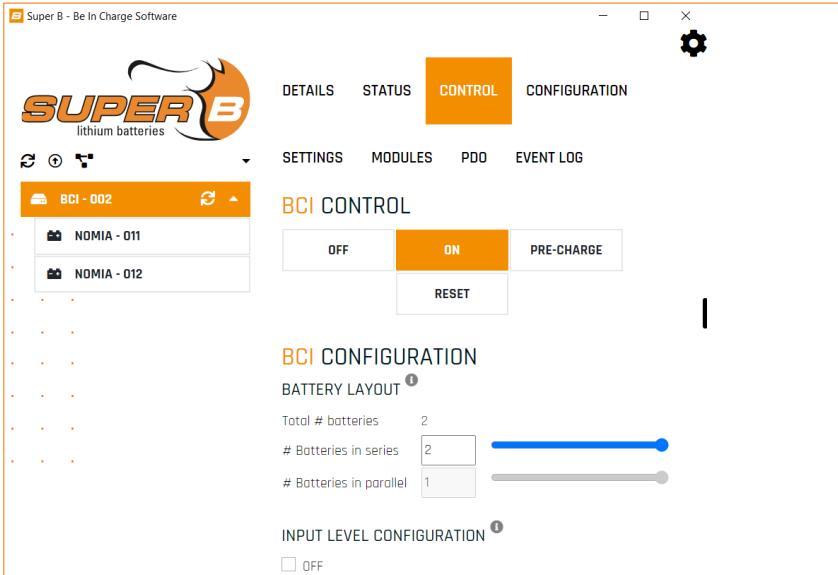

Figure 28. BCI Control tab

The state of the BCI can be manually controlled by using the buttons underneath the BCI Control tab. The reset button can be used to reset the BCI when the BIB and or a Li-ion battery is in error state.

More information about the different state and the corresponding behaviour can be found in chapter 3.4.3.

6.5. Status of the battery bank

The status of the battery bank can be seen in the status tab of the Be in Charge software (see Figure 29 to 35). The information shown in the image is subject to change depending on the Be in Charge software version. They show respectively the BCI in ON state, OFF state (due to battery error), warning state (only available as of BCI SW version 2.35 or later) and 1Ah undervoltage reboot state.

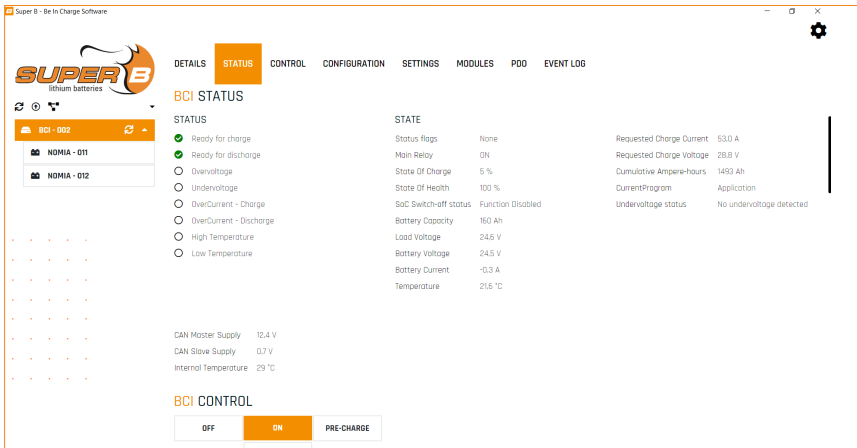

Figure 29. BCI Status tab: ON

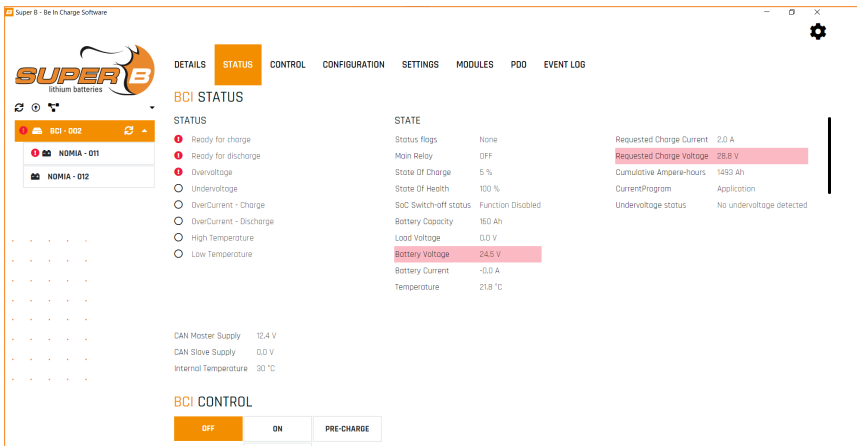

Figure 30. BCI Status tab: OFF – battery in overvoltage

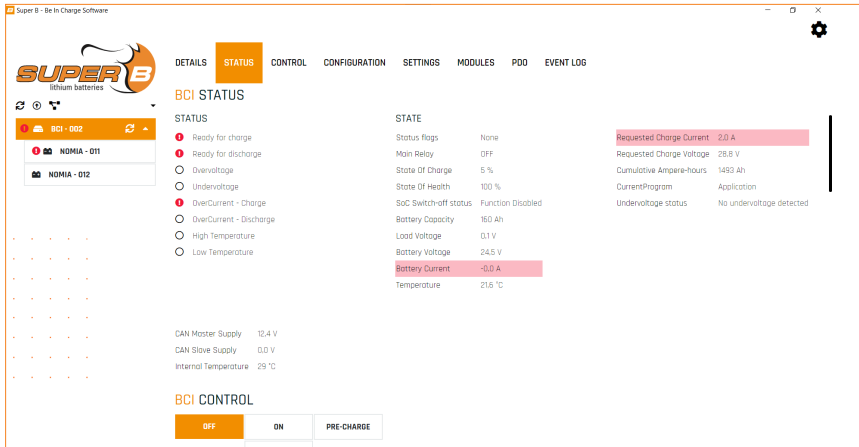

Figure 31. BCI Status tab: OFF – battery in overcurrent while charge

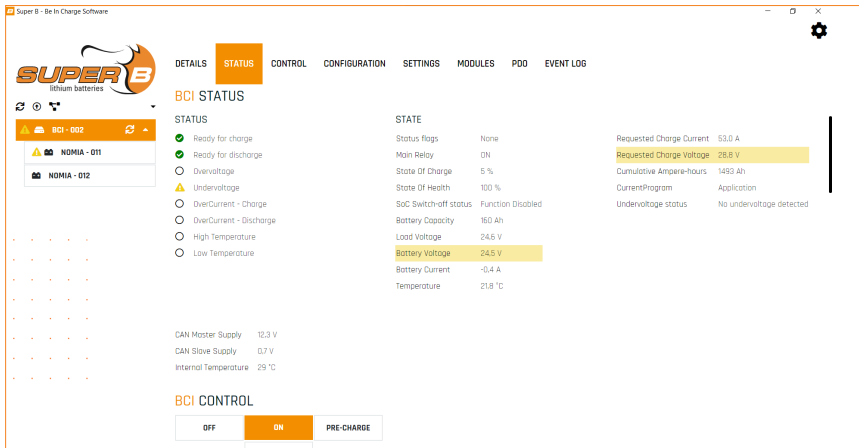

Figure 32. BCI Status tab: undervoltage warning

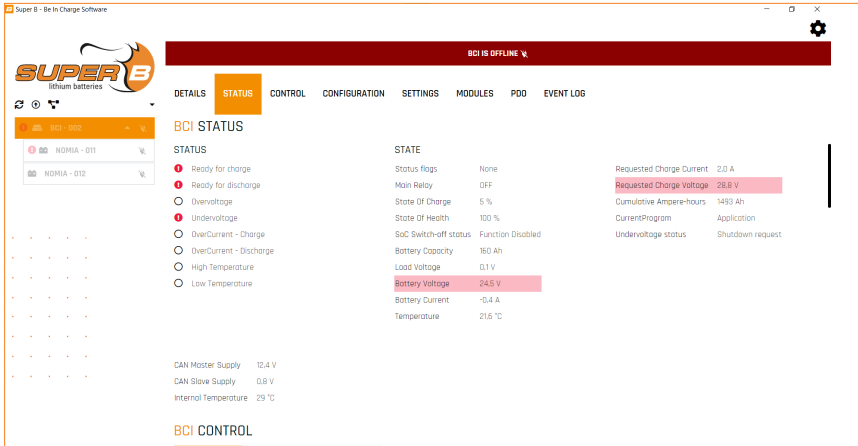

Figure 33. BCI Status tab: undervoltage complete shutdown

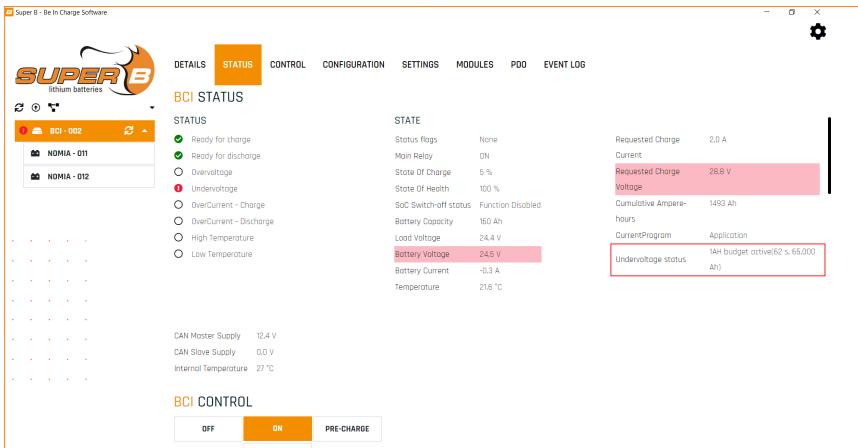

Figure 34. BCI Status tab: 1Ah undervoltage reboot state

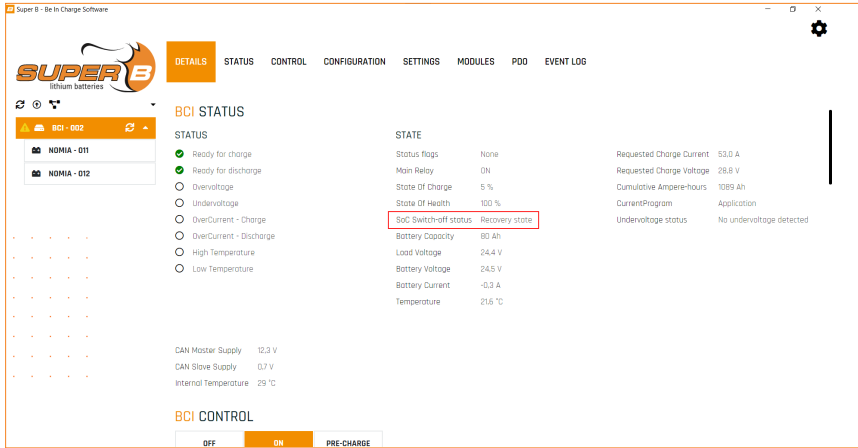

Figure 35. Be in Charge status tab: SoC recovery state as explained in section 3.4.2

7. Inspection and cleaning

7.1. General information

Disconnect the BCI from all loads and Li-ion batteries before performing cleaning and maintenance activities.

7.2. Inspection

Inspect for loose and/or damaged wiring and contacts, cracks, deformations or damage of any other kind. If damage to the BCI is found, it must be replaced. Do not attempt to use a damaged BCI.

7.3. Cleaning

If necessary, clean the BCI with a soft, dry cloth. Never use liquids, solvents, or abrasives to clean the BCI

7.4. Maintenance

The BCI is maintenance free.

8. Storage

Follow the storage instructions in this manual to optimize the lifespan of the BCI during storage. If these instructions are not followed and the BCI is not functioning anymore, consider it to be damaged. Do not attempt to use it. Replace it with a new BCI. No special measures are needed for storage other than observing temperature and humidity requirements (see 4.3).

9. Transport

No special measures or restrictions apply to transport and shipment of the BCI. If it is shipped together with Super B Li-ion batteries, lithium battery legislation applies. In that case, check the manual of the Super B Li-ion battery. Contact your distributor or Super B directly in case of doubt.

10. Disposal

The BCI is classified as “Small IT waste”.

The BCI is compliant with WEEE and RoHS.

WEEE

The European Waste Electrical and Electronic Equipment Directive (WEEE) applies to a wide range of electronic and electrical products. WEEE encourages the collection, treatment, recycling and recovery of waste electrical and electronic equipment. WEEE makes producers and importers responsible for financing of the collection, treatment and recovery of WEEE. Reference: The Waste Electrical and Electronic Equipment (WEEE) Directive 2012/19/EU.

RoHS

The RoHS Directive will ban placement into the EU market of new electrical and electronic equipment containing more than designated maximum allowable levels of lead, cadmium, mercury, hexavalent chromium, polybrominated biphenyl (PBB) and polybrominated diphenyl ether (PBDE) flame retardants, effective June 8th, 2011.

RoHS works in conjunction with the EU WEEE Directive. RoHS supports WEEE by reducing the amount of hazardous chemicals used in production. In turn it reduces the risk of exposure to recycling staff as well as reduction in recycling costs. Manufacturers will need to ensure that their products, parts and components comply with RoHS in order to be distributed and sold in the EU. Reference RoHS Directive 2011/95/EU.

11. Troubleshooting

| Indicator | Meaning | Solution |
|---|--|---|
| Green LED blinking | BCI in bootloader | Check the BCI settings by connecting a PC with the monitor software. Perform a software flash. |
| Green LED blinking with short off intervals | BCI scans for Li-ion batteries | Wait 10 minutes after booting until the blinking stops. |
| Yellow LED blinking | BCI is in pre-charge mode | Configure BCI to ON-state |
| | BCI has just booted and has not yet switched the relays. | Typically the relay should be enabled within 2 minutes. |
| | The difference in voltage between battery bank and charger is too high to safely switch on the main relay. | Wrong configuration of pre-charge system, for example no pre-charge resistor connected or wrong resistor value. Turn off all loads before switching on the BCI. After the BCI is turned on, the loads can be enabled. |
| Yellow LED ON | Main contactor(s) open | Check if BCI is configured for Automatic startup option (Chapter 6.3.6). |
| Red LED is on | One or more Li-ion batteries are reporting an error or the BCI is not configured (first bootup) | Determine which Li-ion battery is reporting the error. Check for excessive heat, any damage, short circuits etc. Take appropriate safety precautions. If the problem has been resolved, reset the system (pushbutton or through the Be in Charge software). |
| | The BCI cannot find one or multiple Li-ion batteries | Check the CAN cables |
| | | Check the CAN terminators |
| | | In case more than 16 Li-ion batteries are connected, check if the external power supply is functional. |
| | | Ensure bitrates are set at 250kbps for each Li-ion battery. |
| Red LED blinking. 1 flash in 1 second | Battery layout configuration incorrect | Doublecheck the battery layout. Does it match completely with the configuration as stored in the BCI? |
| | The BIB is not configured (first bootup) | Follow the steps in paragraph 6.2. |

Table 16. Troubleshooting

If problems persist, contact your Super B representative.



12. Warranty and liability

No rights can be derived from this document. Any installation or use contrary to these instructions may void the warranty granted to you. Please refer to the sales agreement for warranty and other provisions applicable to your purchase. If the product is defective, please contact the dealer, reseller or retailer that you purchased the product from. Super B's liability for any of its products is limited to the corresponding provisions under mandatory applicable law.



For more information please contact:

Super B Lithium Power B.V.
Europalaan 202
7559 SC Hengelo (Ov)
The Netherlands

Tel: +31 (0)88 0076 000
E-mail: info@super-b.com
www: www.super-b.com

